

SPT1009

with hydraulic fly jib

New Height
26m



HENAN SPT MACHINERY
EQUIPMENT CO., LTD.

Mini Crawler Crane (Spider Crane)

International Brand, EU standard
SPT Safe Spider Crane, protecting construction, protecting people

SPT1009 with hydraulic fly jib



Max lifting height 26 m

Weight 12000 kg



Working radius 23 m

Capacity 10.0t×2.5m

SPT1009 with hydraulic fly jib



Working Range Diagram With Fly Jib

SPT1009 Lifting Chart with Fly Jib

Weight: T

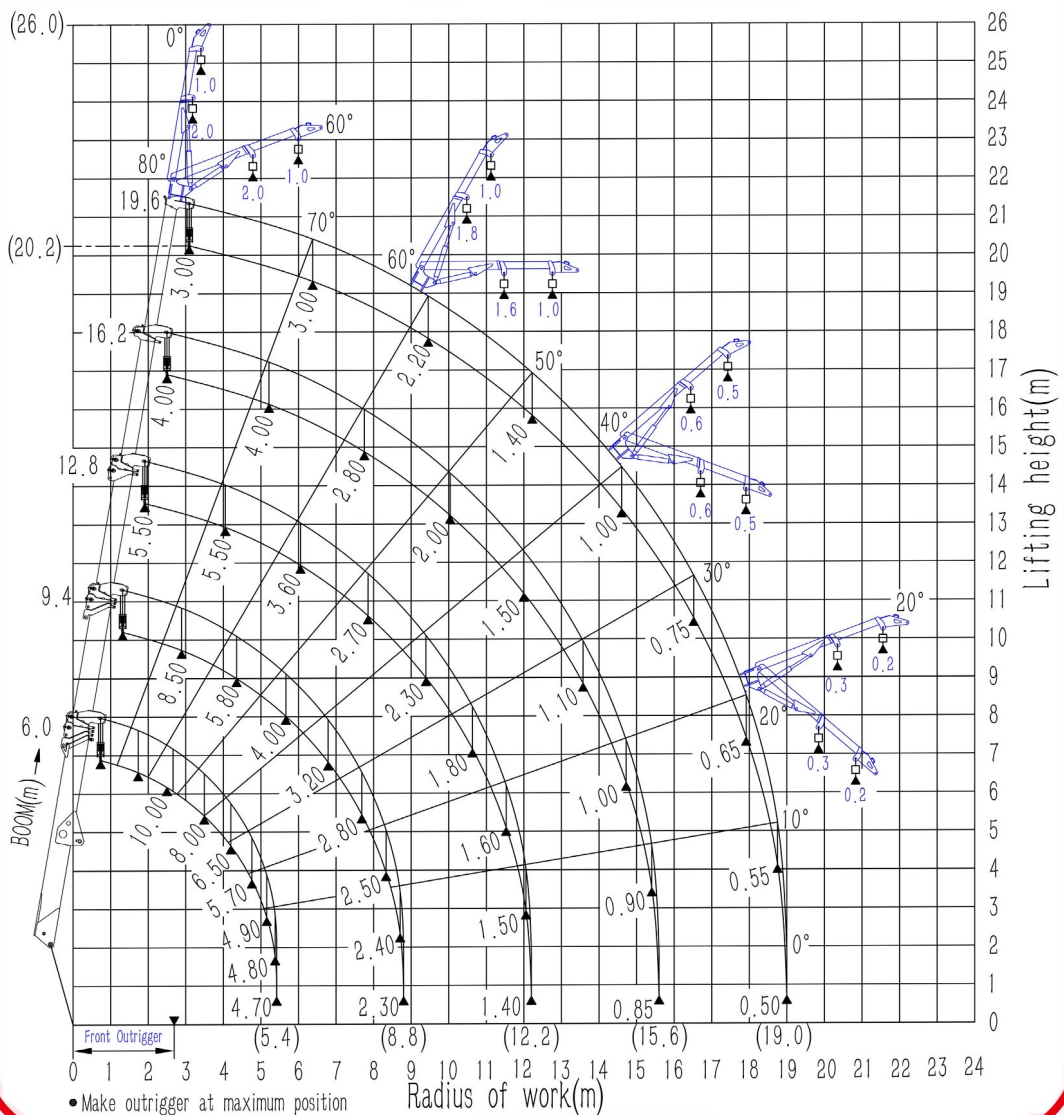

SPT1009 with hydraulic fly jib



Outrigger Footprints

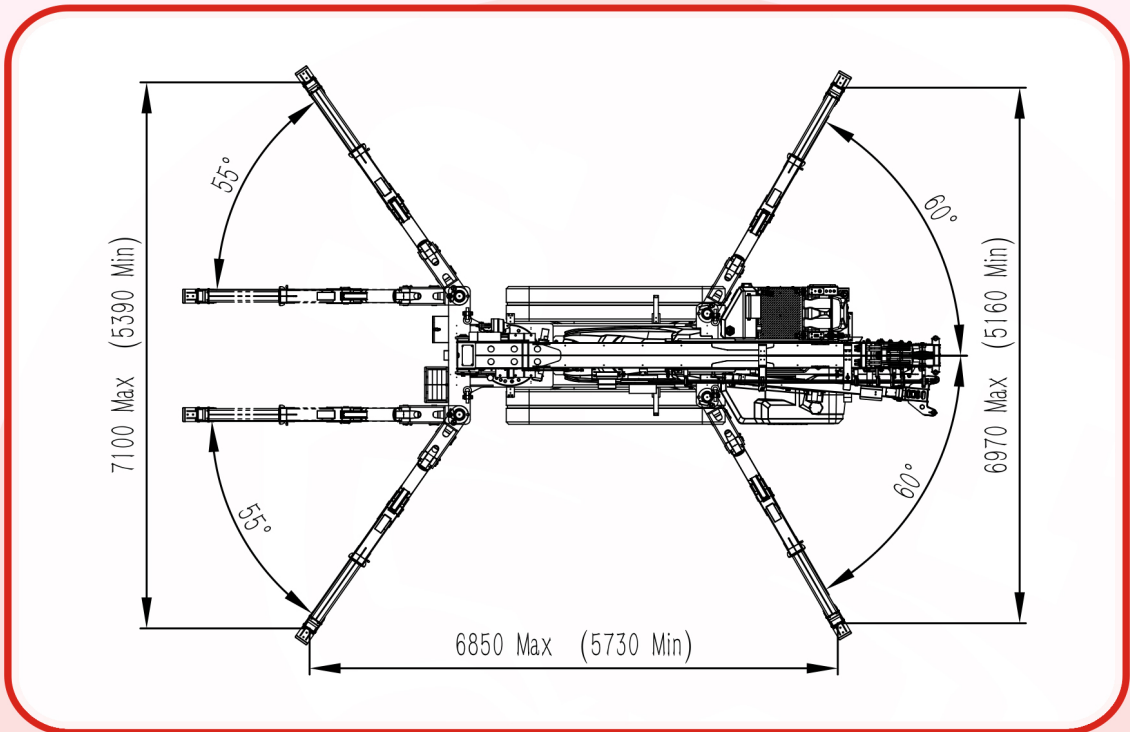

Dimensions

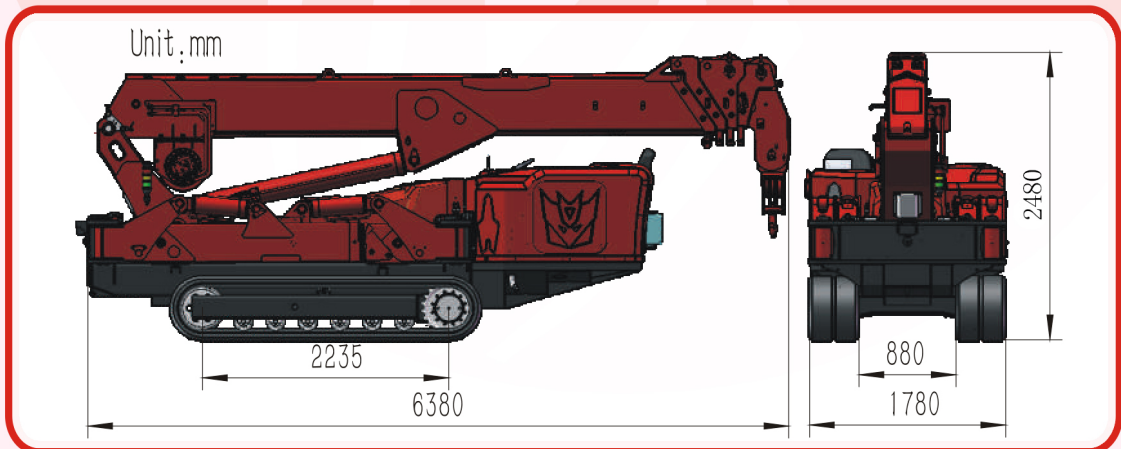

SPT1009 with hydraulic fly jib



Specifications

Model	SPT1009	
Capacity	10.0t × 2.5m	
Working radius	23.0 m	
Ground lifting height	25.0 m	
Underground lifting height	20m-6 fall 30m-4 fall 62m-2 fall 125m-1 fall	
Winch device	Hook speed	0-12m/min (6 fall) 0-18m/min (4 fall)
	Rope type	Φ10mm × 150m
Telescopic system	Boom form	5 section boom, hexagonal box construction
	Boom length/Time	6.0m-19.6m/130 sec
Up and downs	Boom angle/Time	0-80° /80 sec
Slew system	Slew angle/Speed	0-360° (continuous) /120 sec
Outrigger	Outrigger active form	Manual + Hydraulic
	Maximum extended dimensions (mm)	6850 (Length) X7100 (Front) X6970 (Back)
Traction system	Walking way	Hydraulic motor drive、2 speed
	Walking speed	0-2.0 km/h
	Grade ability	23° (42%)
	Ground length × width	2235mm × 400 mm
	Ground pressure	67kpa (0.68 kgf/cm ²)
Electric motor	Voltage	AC380V (Optional)
	Power/Speed	15kw/1440 min-1
	Sound level	Rated speed ≤78dB(A) (1m)
Diesel engine	Model	4TNV88 (YANMAR)
	Type/Displacement	4 Cylinder water cooled/2.19L
	Rated output	29.1kw/2400 min-1
	Starting method	Electric
	Operating temperature	-5° C~40° C
	Fuel/Volume	Diesel/60L
	Battery capacity	12v 190AH
	Specific fuel consumption	239g/kW-h
	Sound Level	Rated speed ≤92dB (A) (1m)
Applied regulation/Altitude	EPA-Tier4, EC stage V/1200m	
Operate system	Type of operation	Wireless remote control and Dual axis joystick controller
	Operating characteristic	Full proportional control
Dimension	Length × Width × Height	6380mm × 1780mm × 2480mm
Weight	(Without optional equipment)	12000 kg
Standard configuration	Diesel engine, Electric motor, Radio remote control, Searcher hook, Hydraulic jib, Black rubber track Intelligent display screen, Moment limiter, Over hoist alarm and automatic stop device, Three-winding alarm and automatic stop device, Automatic hook stow, Outrigger position detector device, Outrigger off the ground alarm and automatic stop device, Slings rope detachment protector, EMO switch, Three color lamp, Remote control lamp, Voice prompt, Walking/Outrigger/Boom three-mode interlock system, Data records, Crane raincoat	
Optional configuration	Glass suction, White rubber track, Single-man basket, Outrigger pads	

SPT1009 with hydraulic fly jib



■ Total rated load Outriggers at Maximum position--Main boom

Working radius (m)	Total rated load (t)				
	6.00 boom	9.40boom	12.80boom	16.20boom	19.60boom
2.50	10.00	8.50	5.50	4.00	—
3.00	9.20	8.50	5.50	4.00	3.00
3.50	8.00	7.50	5.50	4.00	3.00
4.00	6.80	6.40	5.50	4.00	3.00
4.50	6.00	5.60	5.20	4.00	3.00
5.00	5.20	4.80	4.80	4.00	3.00
5.40	4.70	4.60	4.50	3.80	3.00
6.00		3.80	3.60	3.40	3.00
7.00		3.00	3.00	3.00	2.80
8.00		2.60	2.60	2.60	2.60
8.80		2.30	2.30	2.30	2.30
9.50			2.20	2.20	2.20
10.00			2.00	2.00	2.00
11.00			1.70	1.70	1.70
12.20			1.40	1.40	1.40
13.00				1.20	1.20
14.00				1.10	1.10
15.00				1.00	1.00
15.60				0.85	0.85
16.00					0.80
17.00					0.75
18.00					0.65
19.00					0.50