

SPT499

with hydraulic fly jib

New Height
23m



HENAN SPT MACHINERY
EQUIPMENT CO., LTD.

Mini Crawler Crane (Spider Crane)

International Brand, EU standard

SPT Safe Spider Crane, protecting construction, protecting people

SPT499 with hydraulic fly jib



Max lifting height 23 m



Capacity 5.0t×3.0m

Weight 6450 kg

Working radius 20.5 m

SPT499 with hydraulic fly jib



Working Range Diagram With Fly Jib

SPT499 Lifting Chart with Fly Jib

Weight: T

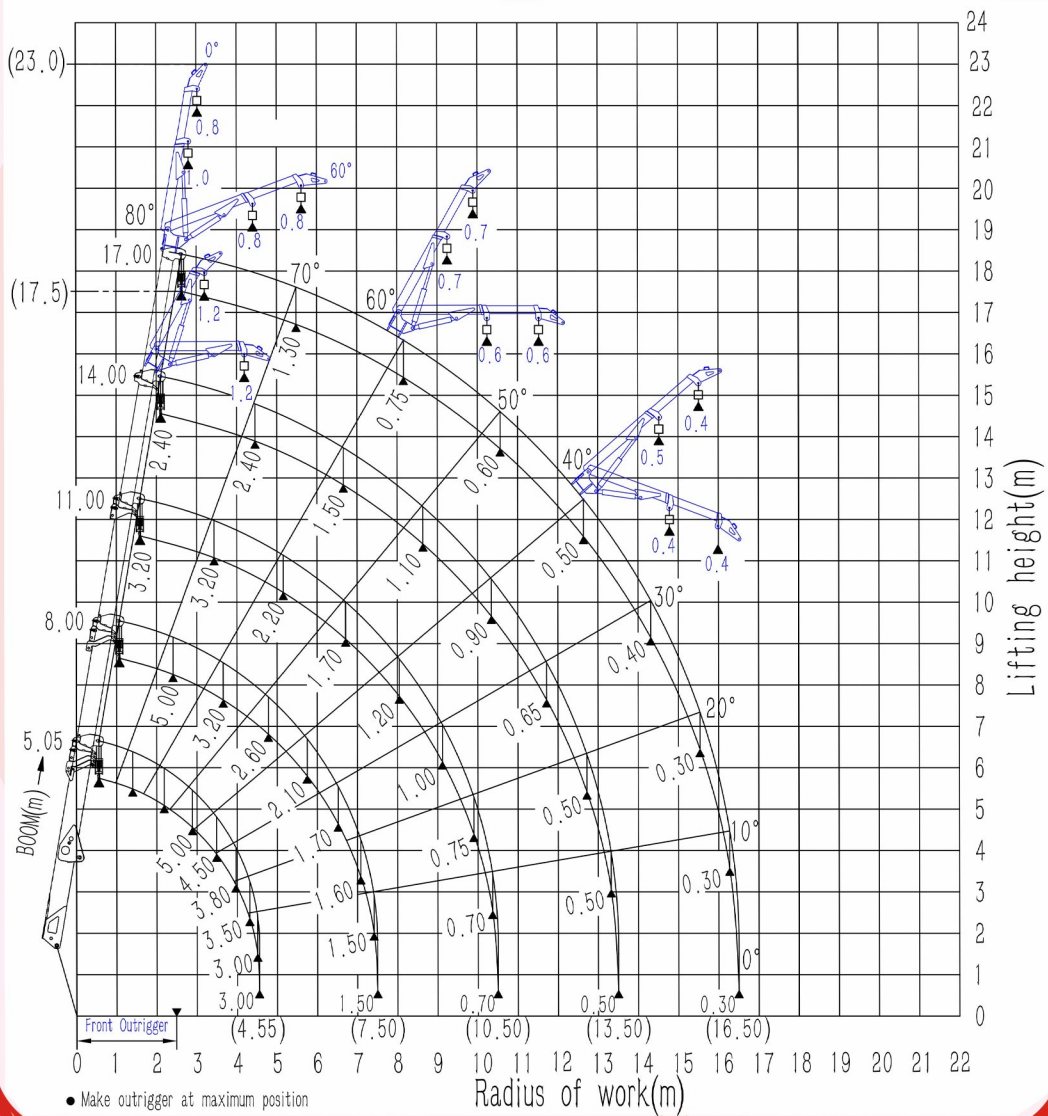

SPT499 with hydraulic fly jib



Outrigger Footprints

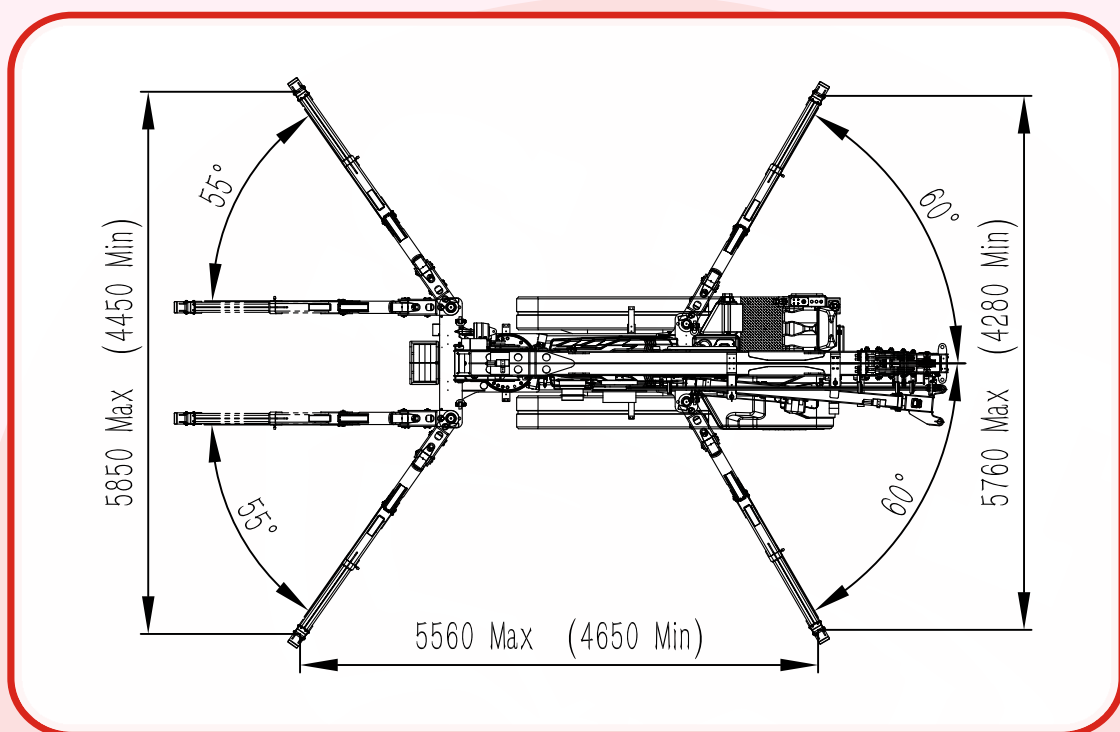

Dimensions

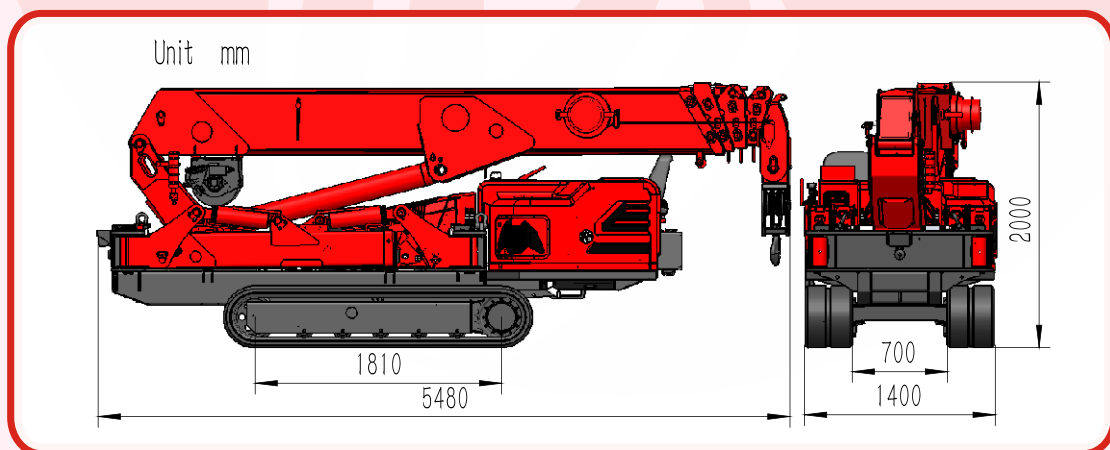

SPT499 with hydraulic fly jib



Specifications

Model		SPT499
Capacity		5.0t × 3.0m
Working radius		20.5 m
Ground lifting height		23.0 m
Underground lifting height		17.5mX2.5t 4falB5mX2t2fall70mX1t1fall
Winch device	Hook speed	0-14m/min (4 fall)
	Rope type	Φ10mm × 80m
Telescopic system	Boom form	5section boom, hexagonal box construction
	Boom length/Time	5.05m-17.00m/45sec
Up and downs	Boom angle/Time	0-80° /18sec
Slew system	Slew angle/Speed	0-360° (continuous)/30sec
Outrigger	Outrigger active form	Manual+Hydraulic
	Maximum extended dimensions (mm)	5560(Length)X5850(Front)X5760(Back)
Traction system	Walking way	Hydraulic motor drive、 2 speed
	Walking speed	0-2.5km/ h
	Grade ability	20° (36%)
Electric motor	Ground length × width	1810mm × 350 mm
	Ground pressure	51kpa(0.52 kg/cm ²)
	Voltage	AC380V(Optional)
Diesel engine	Power/Speed	7.5kw/1440 min-1
	Sound level	Rated speed ≤78dB(A) (1m)
Diesel engine	Model	D1703(Kubota)
	Type/Displacement	3 cylinder water cooled/ 1.6L
	Rated output	18.2kw/2200rpm
	Starting method	Electric
	Operating temperature	-5° C-40° C
	Fuel/Volume	Diesel/40L
	Battery capacity	12V 60AH
	Specific fuel consumption	254g/kwh
	Sound Level	Rated speed ≤ 90 dB (A)(1m)
Operate system	Applied regulation/Altitude	EPA-Tier4, EC stage V/1200m
	Type of operation	Wireless remote control and Dual axis joystick controller
Dimension	Operating characteristic	Full proportional control and Proportional joystick control
	Length × Width × Height	5480mm × 1400mm × 2000mm
Weight	Without optional equipment	6450 kg
Standard configuration	Diesel engine, Electric motor, Radio remote control, Searcher hook, Hydraulic jib, Black rubber track, Intelligent display screen, Moment limiter, Over hoist alarm and automatic stop device, Three-winding alarm and automatic stop device, Automatic hook stow, Outrigger position detector device, Outrigger off the ground alarm and automatic stop device, Slings rope detachment protector, EMO switch, Three color lamp, Remote control lamp, Voice prompt, Walking/Outrigger/Boom three-mode interlocksystem, Data records, Crane raincoat	
Optional configuration	Glass suction, White rubber track, Single-man basket, Outrigger pads	

SPT499 with hydraulic fly jib



■ Total rated load Outriggers at Maximum position--Main boom

Working radius m	Total rated load (t)				
	5.05 boom	8.00boom	11.00boom	14.00boom	17.00boom
2.50	5.00	5.00	3.20	2.40	—
3.00	5.00	4.00	3.20	2.40	1.30
3.50	4.50	3.30	3.20	2.40	1.30
4.00	3.80	3.00	3.00	2.40	1.30
4.55	3.00	2.70	2.70	2.40	1.30
5.00		2.50	2.20	2.20	1.30
6.00		2.00	1.90	1.60	1.00
7.00		1.60	1.60	1.40	0.90
7.50		1.50	1.40	1.30	0.80
8.00			1.20	1.20	0.75
9.00			1.00	1.10	0.70
10.00			0.75	0.95	0.65
10.50			0.70	0.90	0.65
11.00				0.70	0.60
12.00				0.65	0.55
13.00				0.50	0.50
13.50				0.50	0.45
14.00					0.40
15.00					0.35
16.00					0.35
16.50					0.30